

## 1. Antriebskonzept TCS

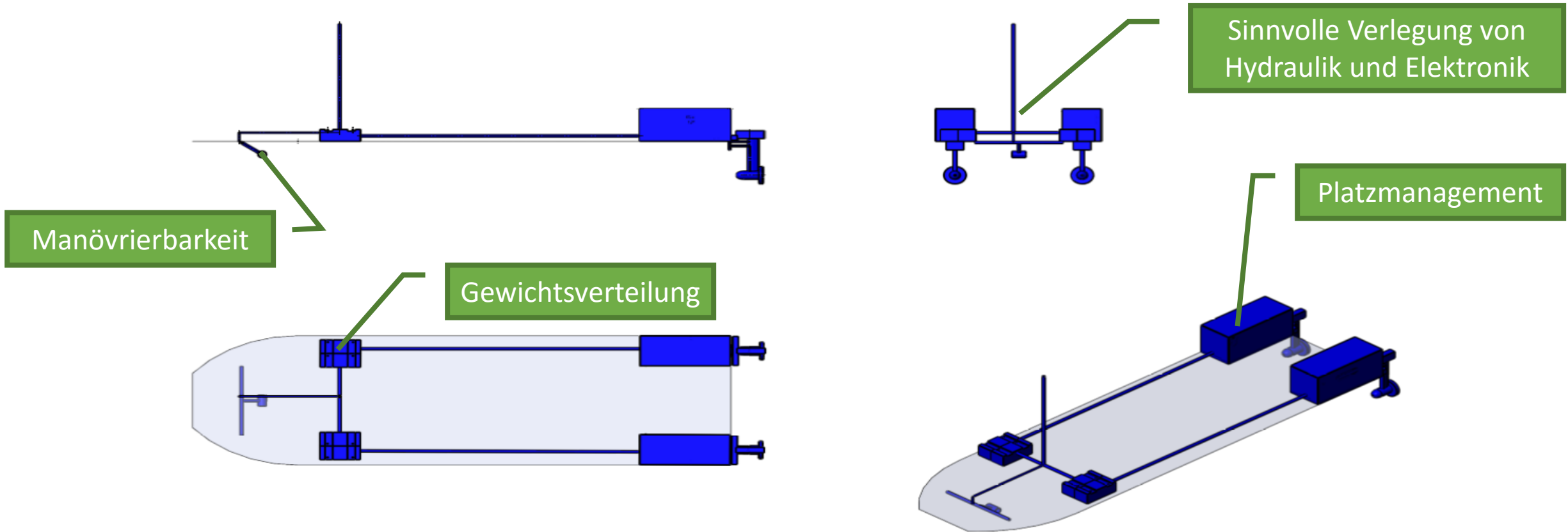

## 2. Antriebskonzept TCS

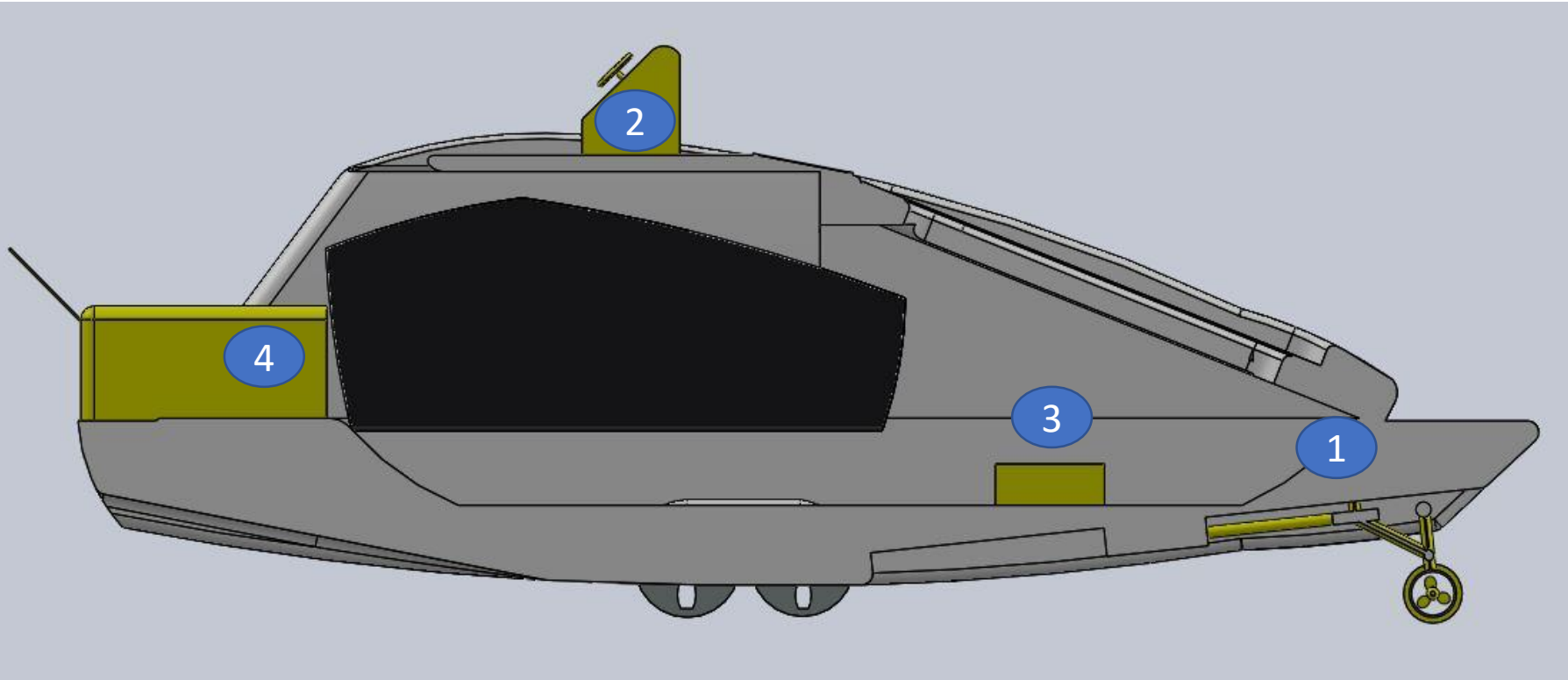

- 1 Bugstrahlruder  
(einfahrbar)
- 2 Flybridge
- 3 4 x Batterien
- 4 Motorgarage  
(Hauptbestandteil TCS)

## 3. Antriebskonzept TCS

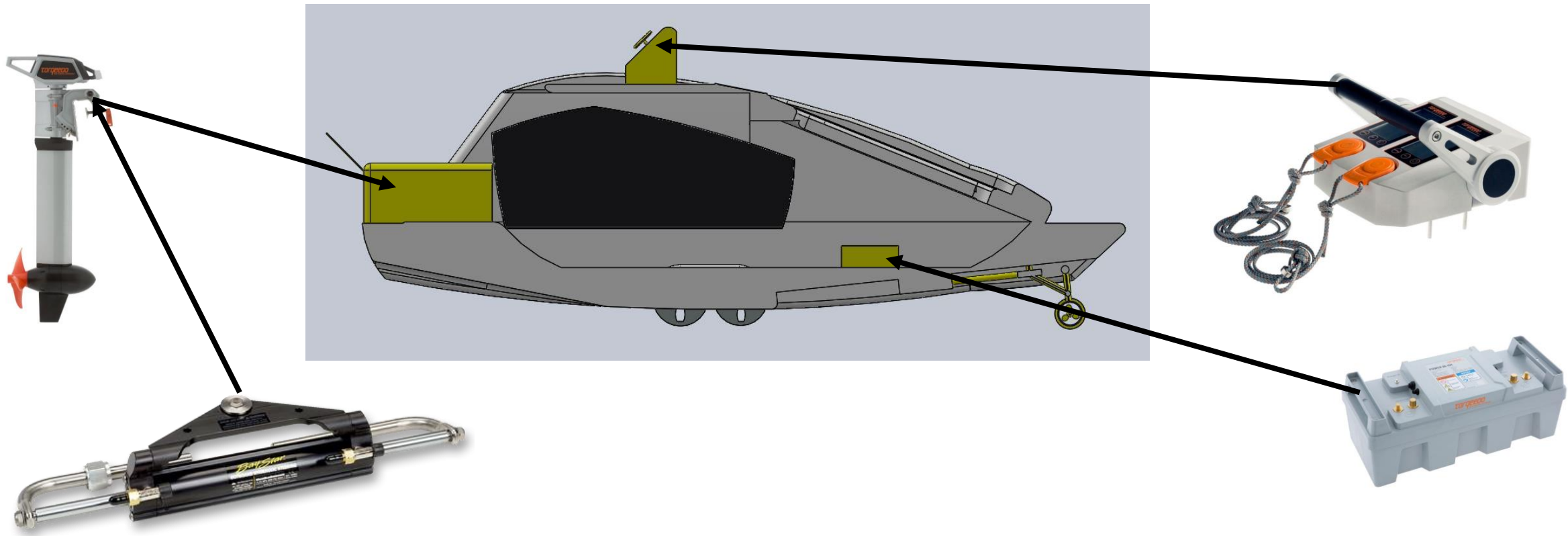

## 4. Antriebskonzept TCS

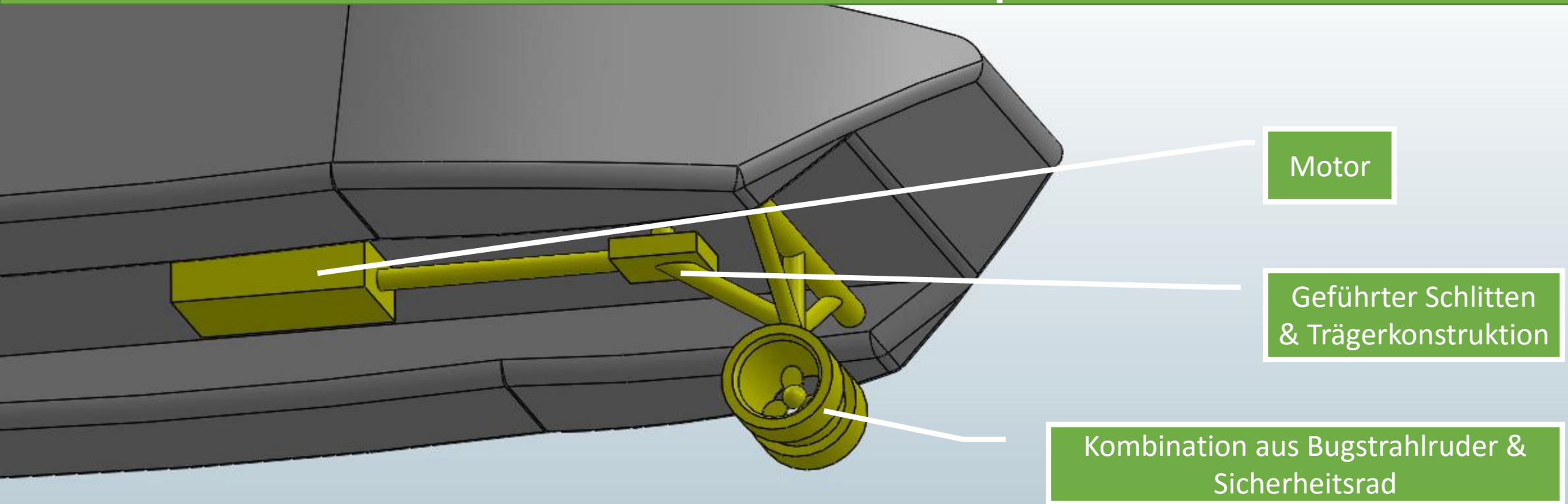



## 5. Motorgarage TCS

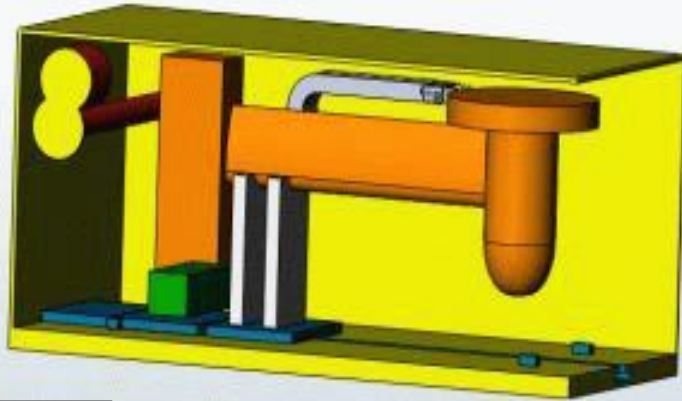

- Rot: Einzugsmechanismus
- Blau: Schlittenmechanik
- Orange: Außenborder
- Weiß: Halterung
- Gelb: Motorgarage
- Grün: Lenkeinheit
- Grau: Energiekette

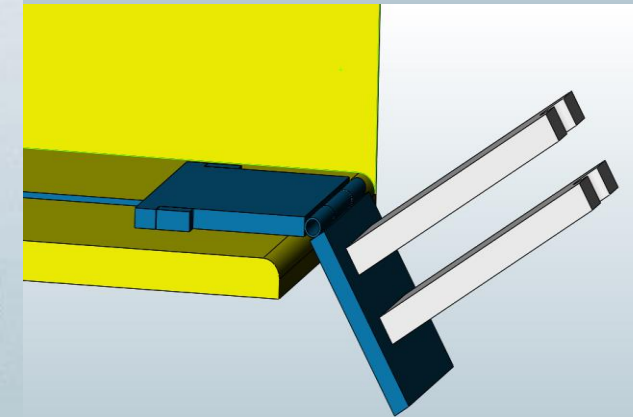
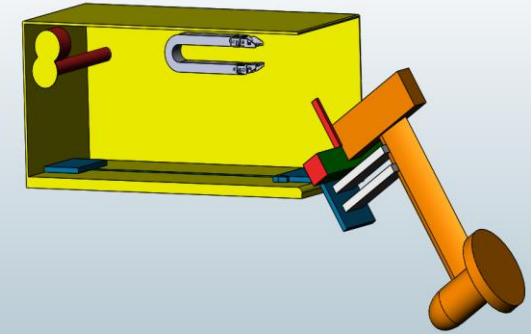

## 6. Einrichtung & Gadgets

Solaranlage

Anker über Seilwinde

Positions- & Ankerleuchten

LED-Beleuchtung

Wassertank

Durchlauferhitzer

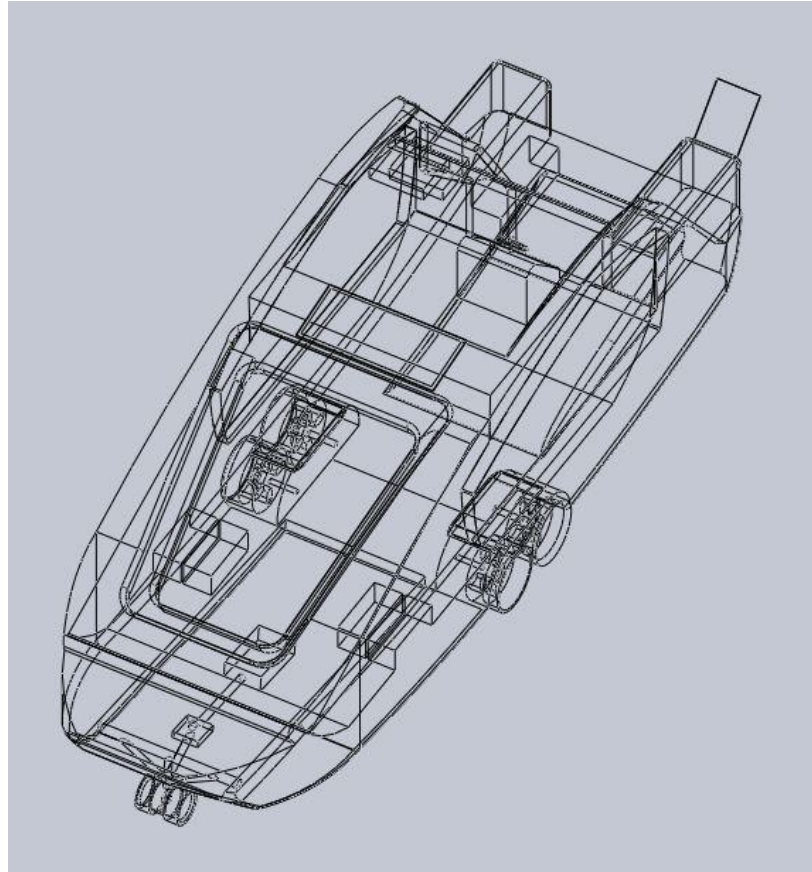

Fußbodenheizung

Multimedia-System

Soundsystem

Smart-Home

Kühlschrank

Multifunktionsrampe

## 7. Sicherheit & Benutzerfreundlichkeit

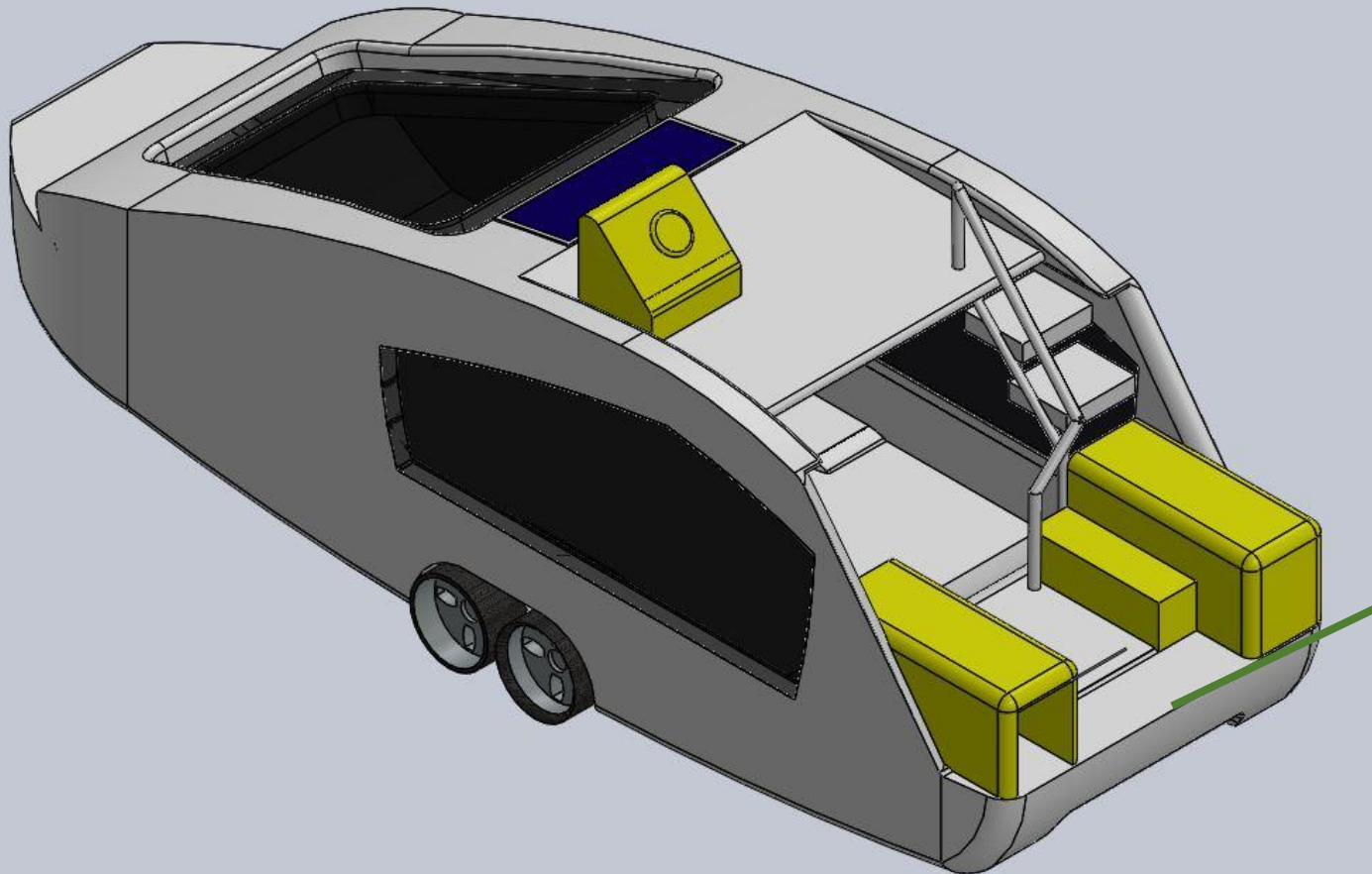

Multifunktionsrampe gewährleistet:

- Einfache Beladung & Entladung
- barrierefreier Zugang

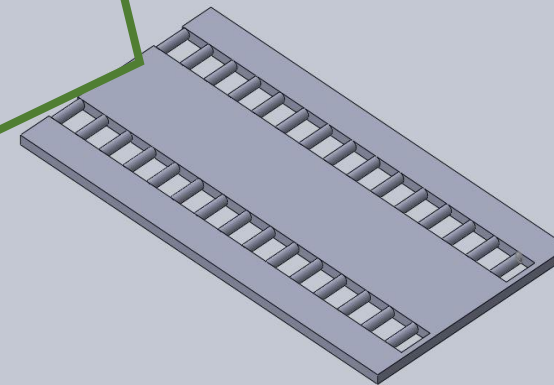



## 8. Kostenrechnung pro Jahr

Gesamte Entwicklungskosten	13.440,00€
Materialkosten	358.460,00€
Lohnkosten inkl. Maschinen	200.000,00€
Gesamte Gemeinkosten	-
Gesamtkosten	601.900,00€
Umsatz (10 à 110.000,00€)	1.100.000,00€
Gewinn	498.100,00€

Team  
Edith  
Clarke

Twin  
Comfort  
System

