

Herzlich Willkommen!



10 9 8 **7** 6 5 4 3 2 1

startIng!

Danfoss

NORDMETALL

Verband der Metall- und
Elektroindustrie e.V.



Ministerium für Bildung
und Wissenschaft
des Landes Schleswig-Holstein



Skizze

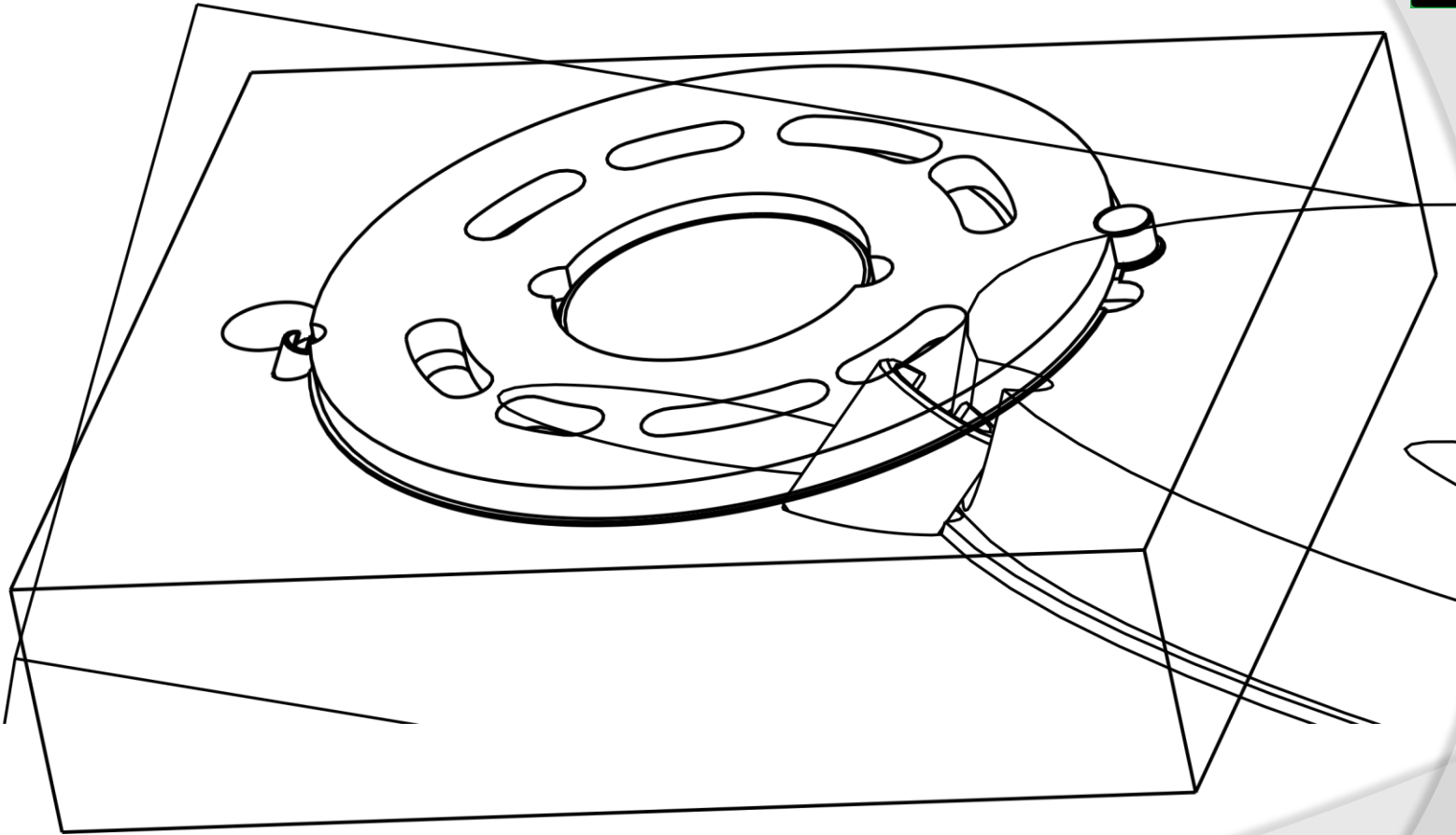

Schnittansicht

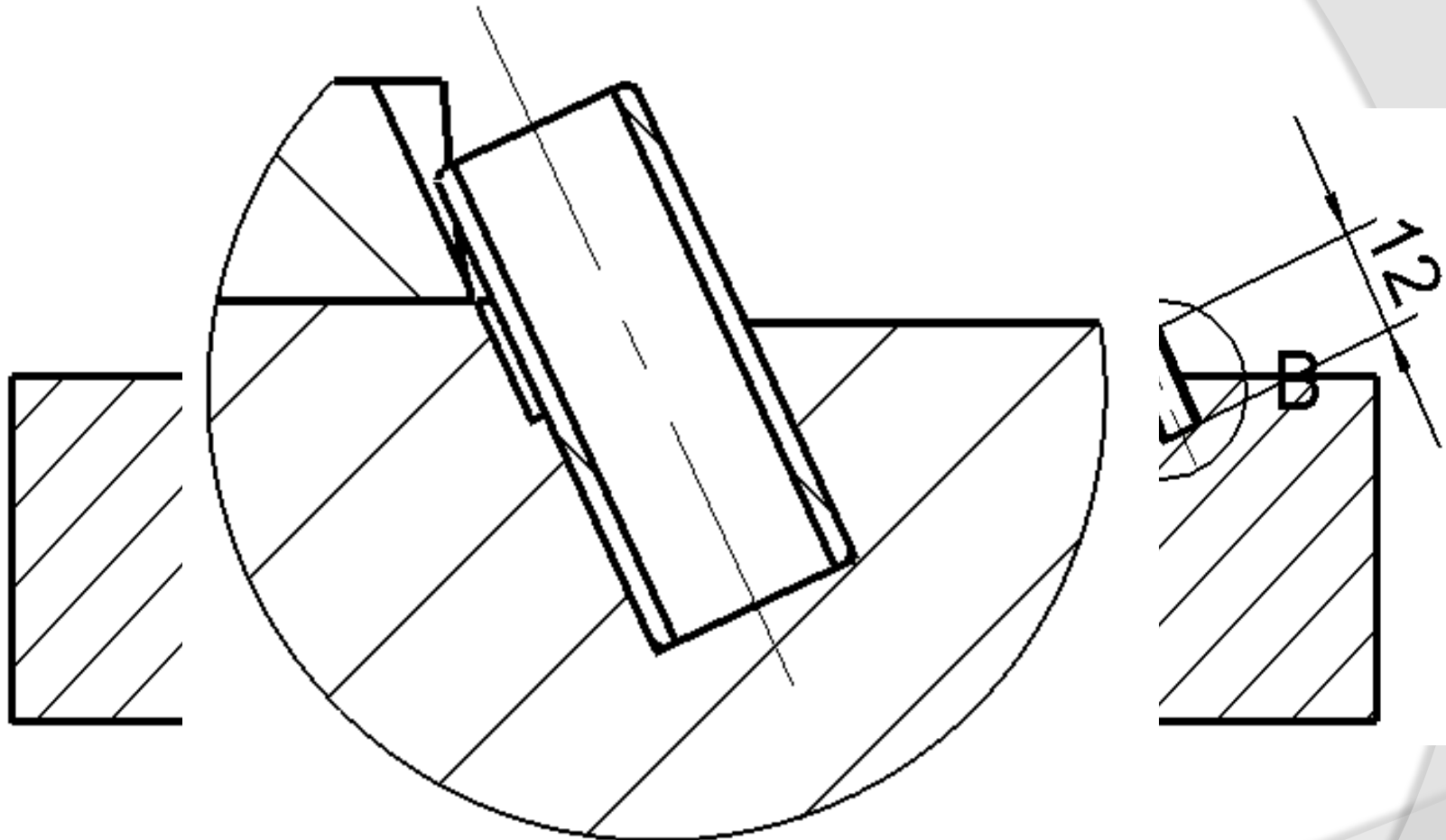



Montageablauf

Montage:

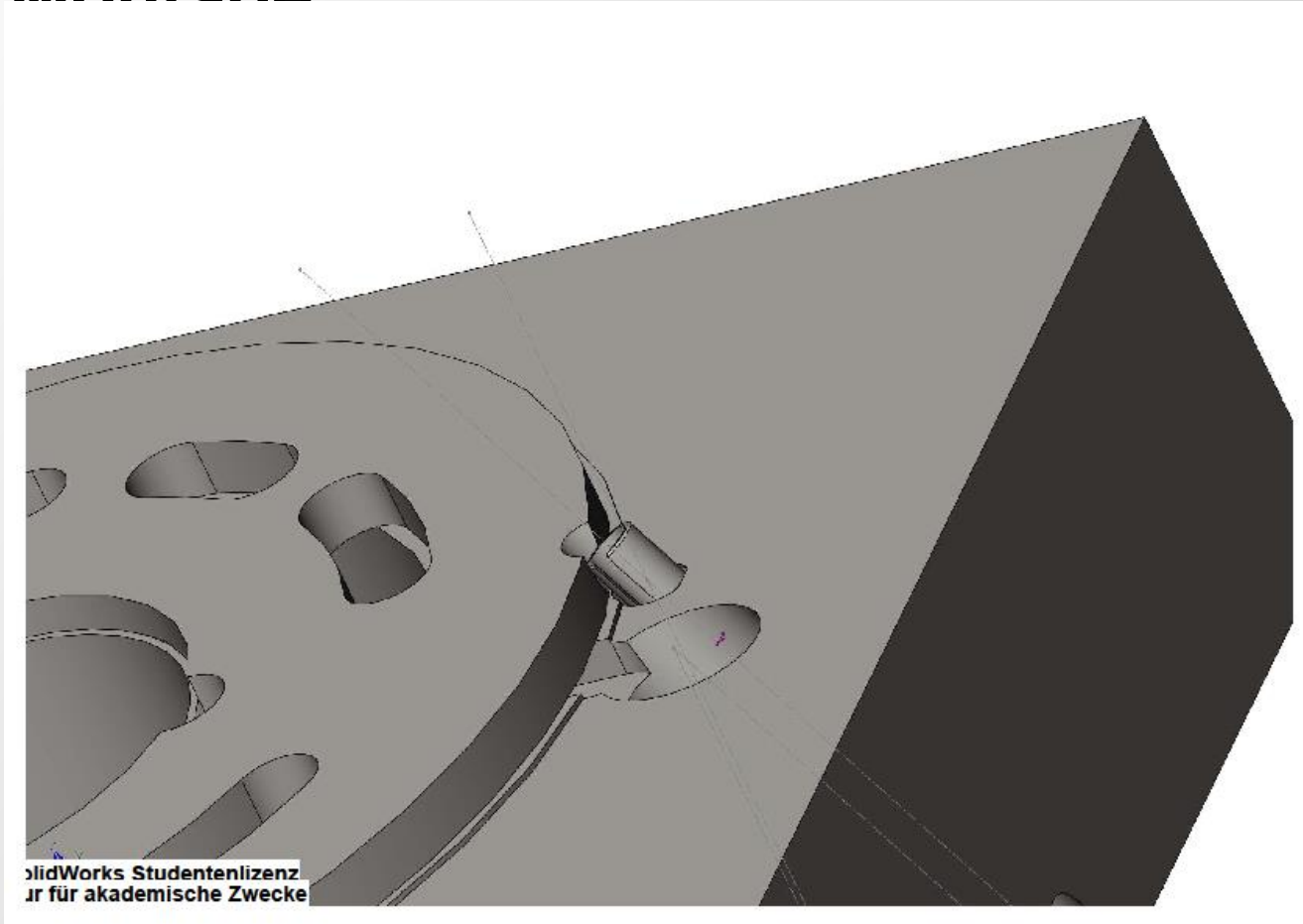

Power Pin

- Die geforderten „Muss-Kriterien“ werden erfüllt
- Schnelle Montage
- Hält auch bei Demontage
- Sicherer als Vaseline
- Kostengünstige Alternative



Wirtschaftlichkeit



Rentierung nach Ausfällen beim Kunden

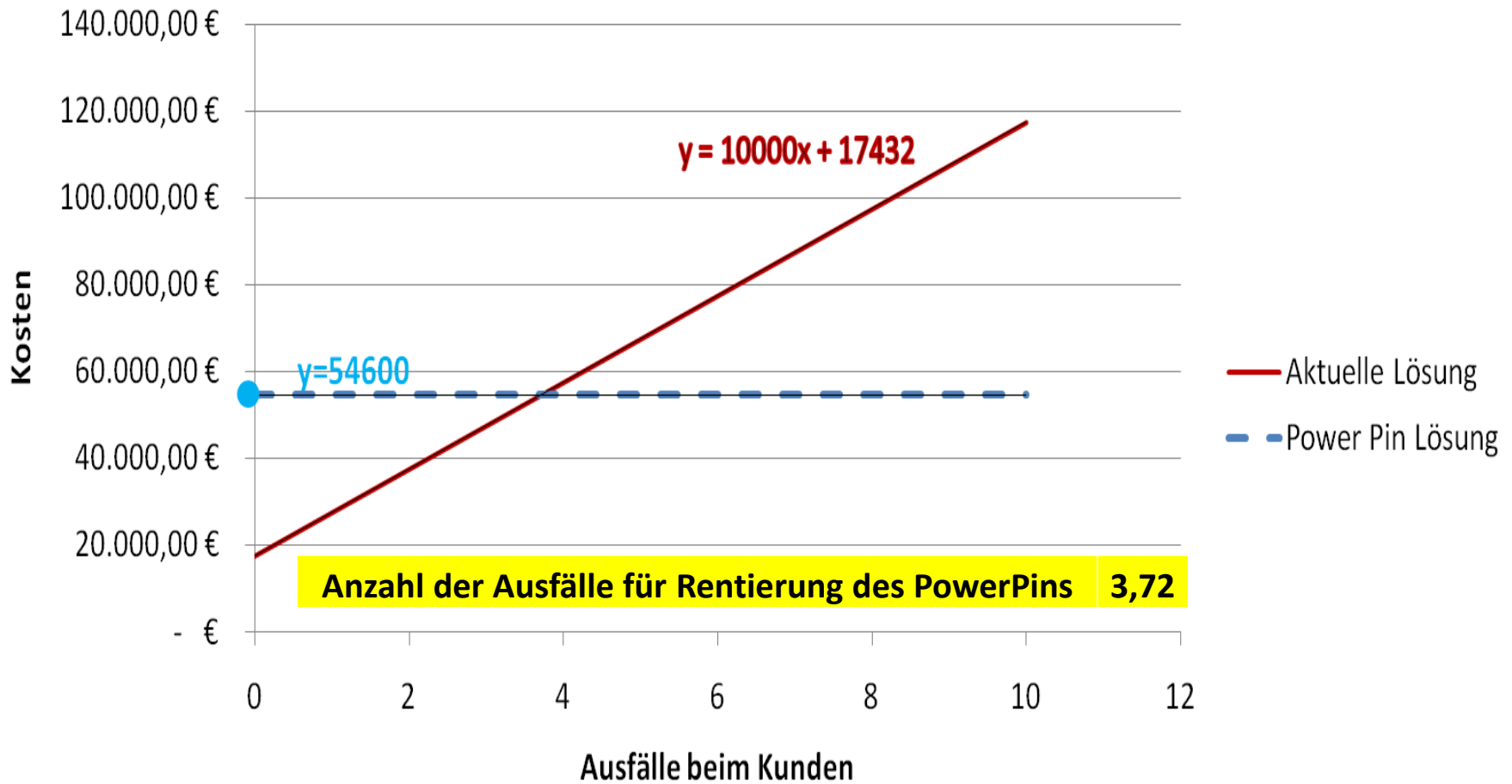

*Power
in*

-das bleibt drin!