



Optimierung der Ventilplattenmontage H1 P



Ministerium für Bildung
und Wissenschaft
des Landes Schleswig-Holstein



Gliederung

1. Gesamtsystem
2. Teilsystem Schraube
3. Kostenberechnung
4. Montagehilfe
5. Vorteile

Das Gesamtsystem

Verdrehsicherung mit Haltefunktion

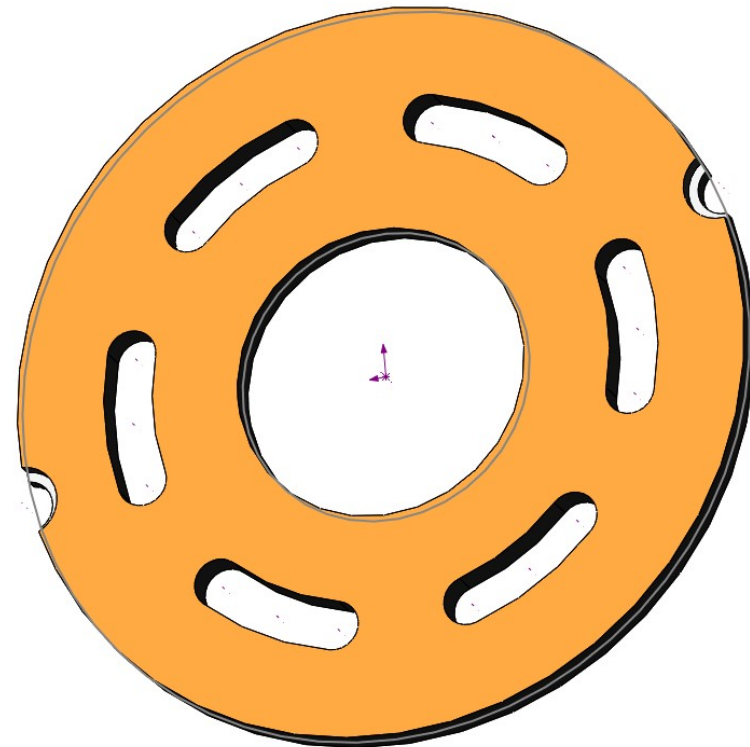
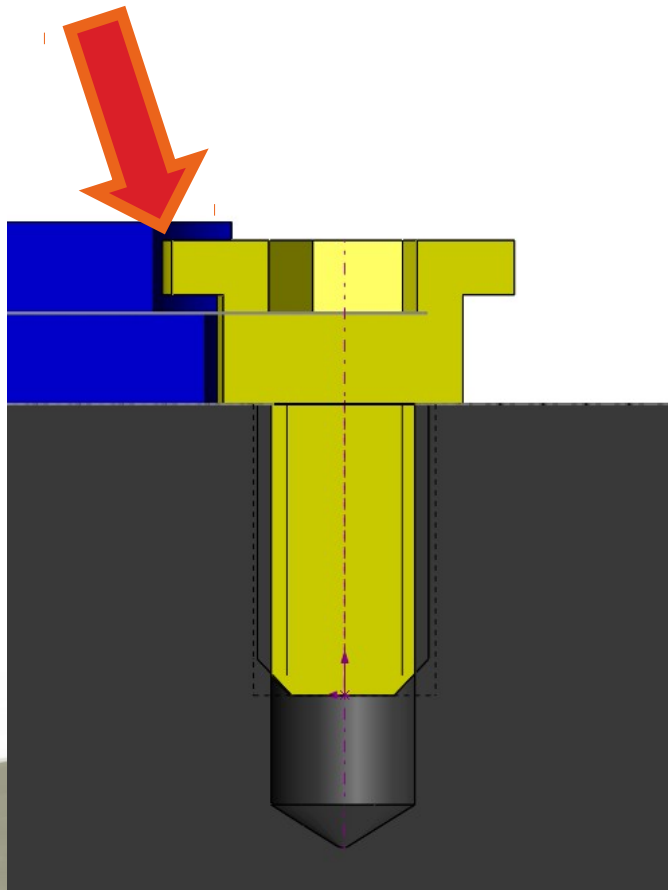

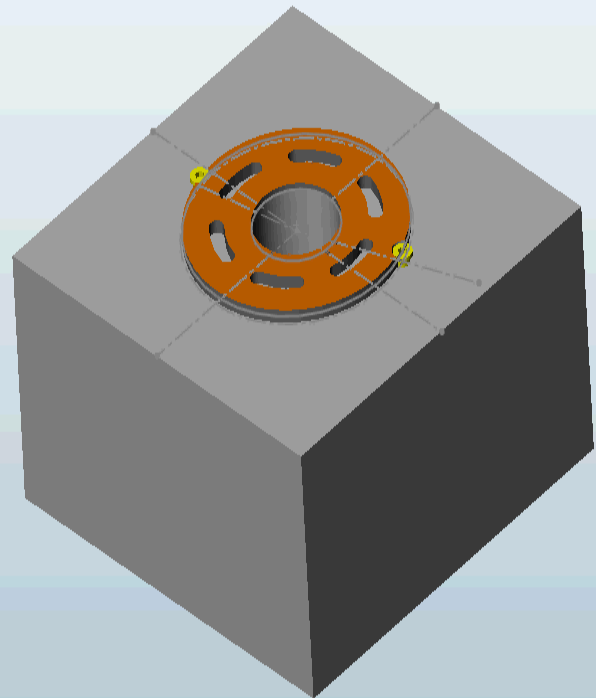

Teilsystem Schraube

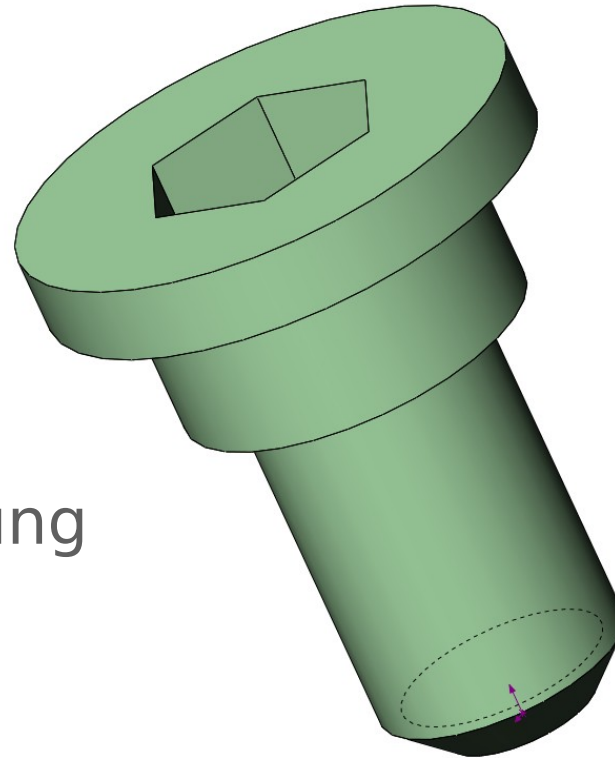

Spezialanfertigung
M5 aus C 15 E
Innensechskant

Kostenberechnung für ein Jahr

1.	Materialkosten	66.056,- €
2.	Lohnkosten inkl. Maschinen	5.555,- €
3.	Entwicklungskosten (verteilt auf 3 Jahre)	23.650,- €

Summe Kosten	95.261,- €
--------------	------------

Einsparungen
31.006,- €

Verbleibende Kosten	64.255,- €
---------------------	------------

Verkaufte Stückzahl	20.000 Stk
---------------------	------------

Summe Mehrkosten/Pumpe

Montagehilfe

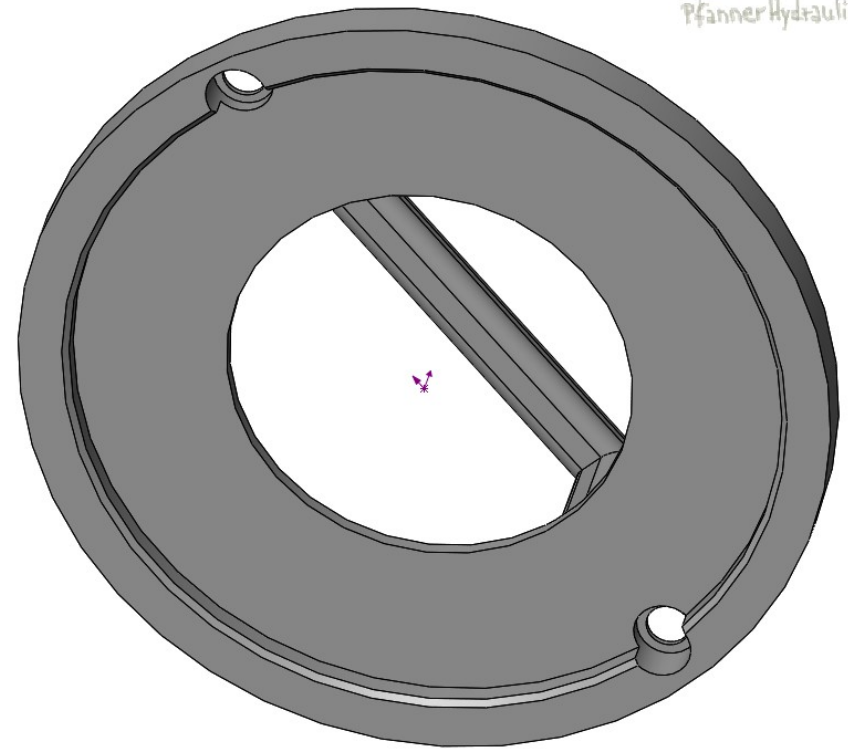
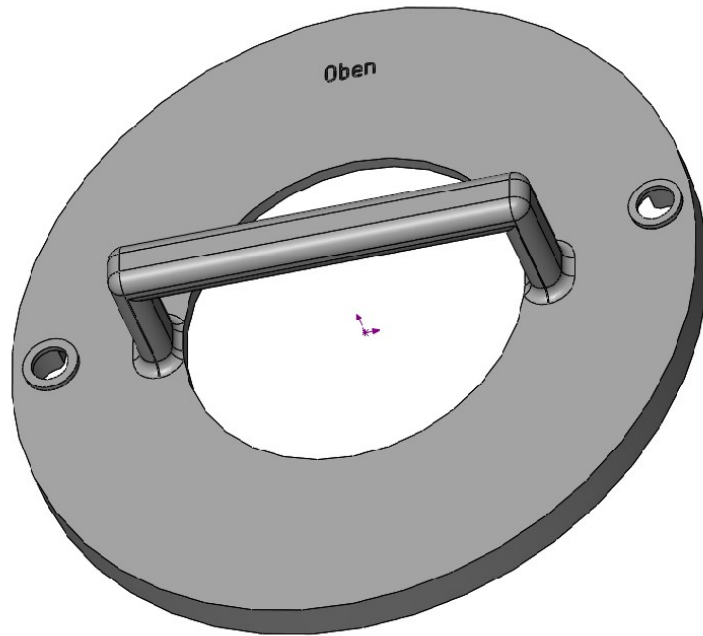

Vorteile

- ▶ Kein Imageverlust!
- ▶ 100% Montagesicherheit
- ▶ Keine falsche Montage möglich
 - Versetzte Löcher
 - Montagehilfe
- ▶ Keine Rückstände
- ▶ Wartungsfreundlich

Fragen?

Ruth Lübke

Ewa Czerniawski

Janina Borowski

Merlin Sophia Uhlig

Max Morschheuser

Leon Will

Ramon Bogolnicki

